

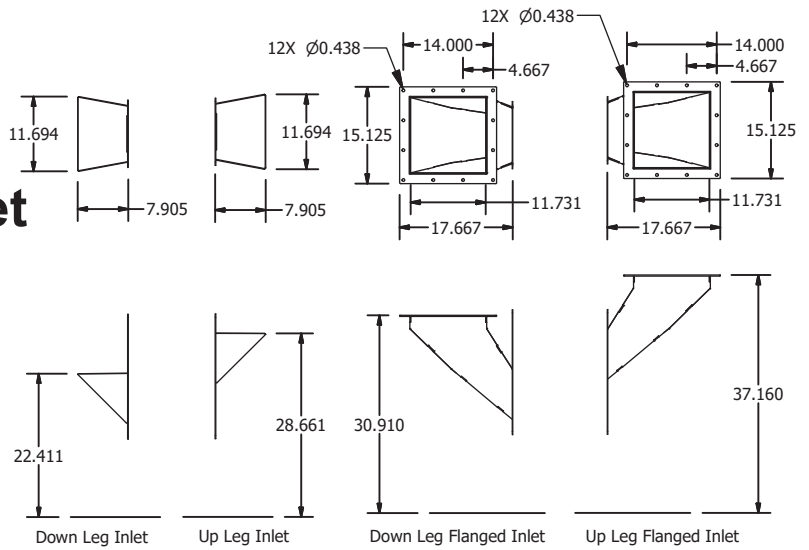

OPTIONAL: INLET PANELS



Bucket Elevator Spec Sheet
1200 series Chain Drive

Bushels per hour

| | 1000* | 1500 | 2000* |
|-----------------------|---------|---------|---------|
| Cup Size | 7" x 5" | 7" x 5" | 7" x 5" |
| Cup Spacing | 12" | 6" | 6" |
| Head Shaft RPM | 192 | 175 | 192 |
| Belt FPM | 629 | 573 | 629 |

* Only Belt Drives & Chain Drives Available as Pulleys/Sprockets are used to Speed up Belt to desired Capacity

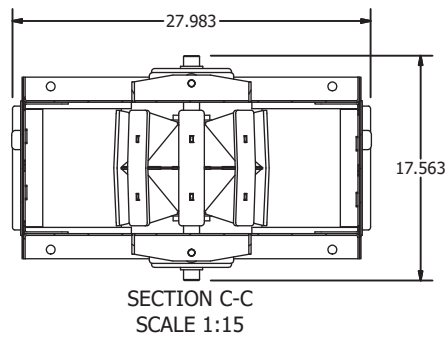
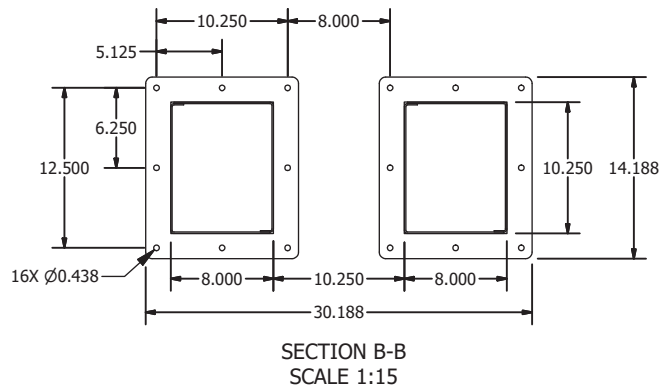
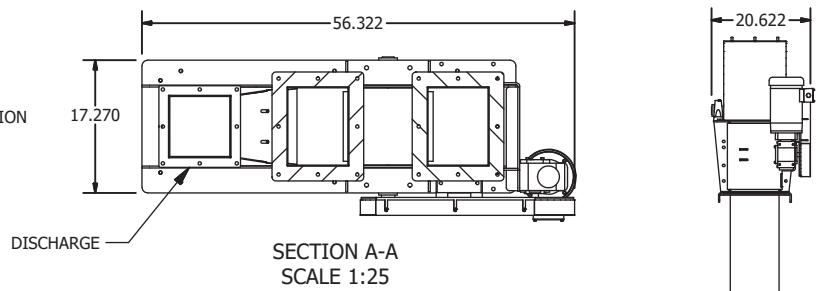
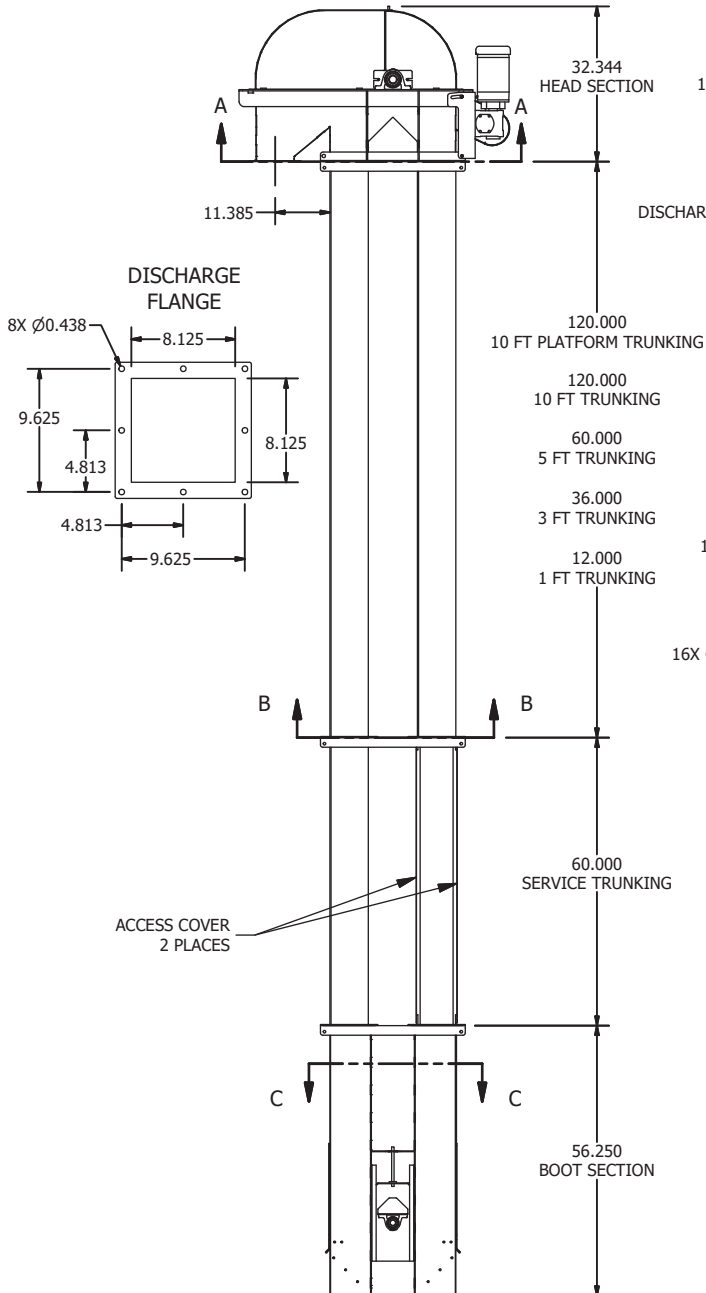

12" Drum x 9" Wide

