



Bucket Elevator Spec Sheet

1600 series

Bushels per hour

	2500	3000
Cup Size	9" x 6"	10" x 6"
Cup Spacing	7 3/4"	7"
Head Shaft RPM	95	95
Belt FPM	418	418

OPTIONAL: INLET PANELS

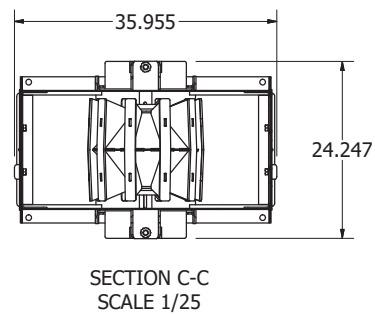
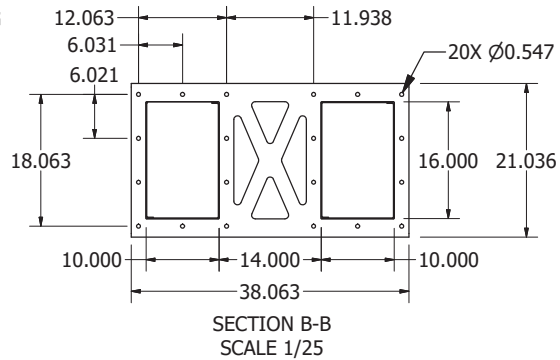
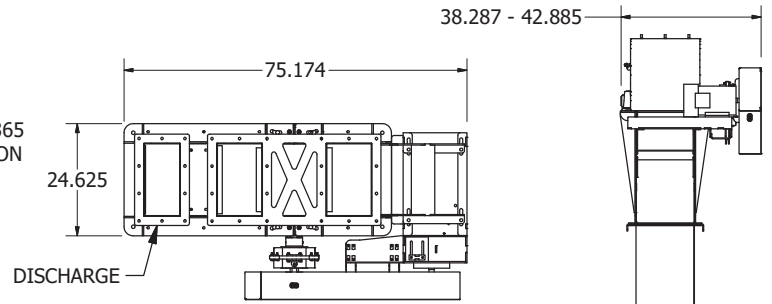
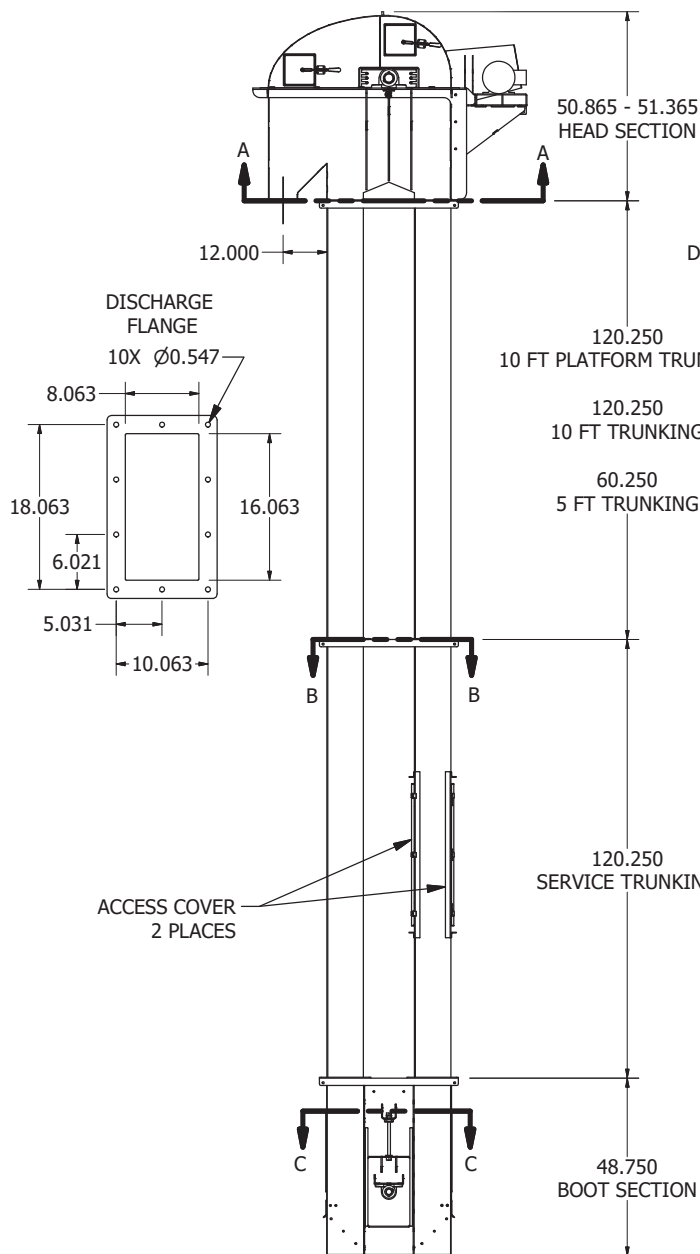
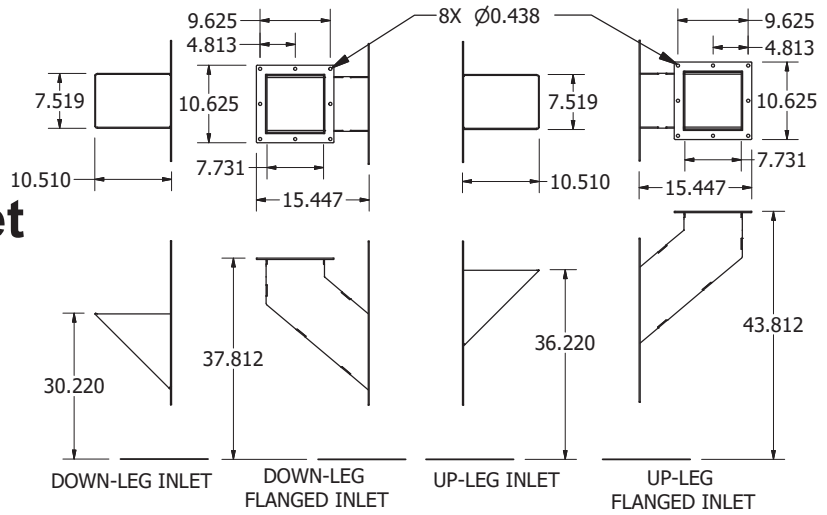

16" DRUM X 14" WIDE

CLEAN OUT DOOR BOTH SIDES

