



OPTIONAL: INLET PANELS

# Bucket Elevator Spec Sheet

## 800 series Belt Drive

**Bushels per hour**

	500	700	1000
Cup Size	6" x 4"	6" x 4"	6" x 4"
Cup Spacing	12"	6"	6"
Head Shaft RPM	175	115	175
Belt FPM	358	235	358

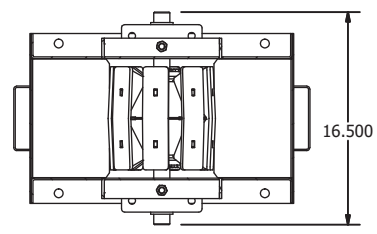
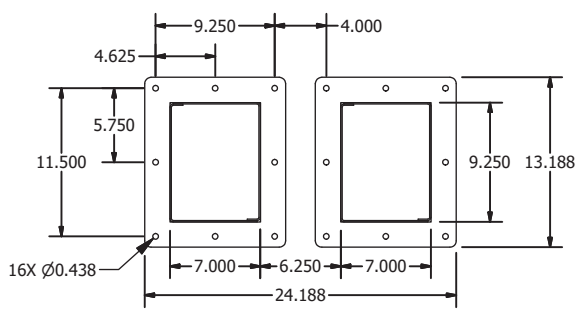
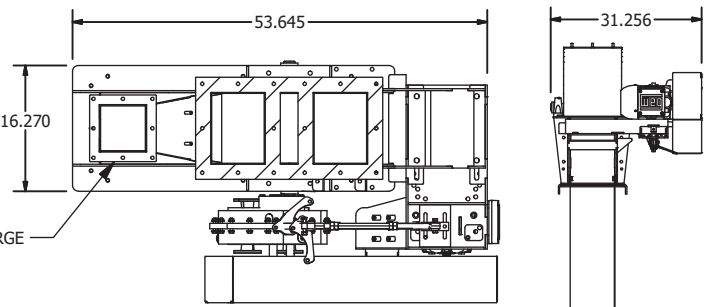
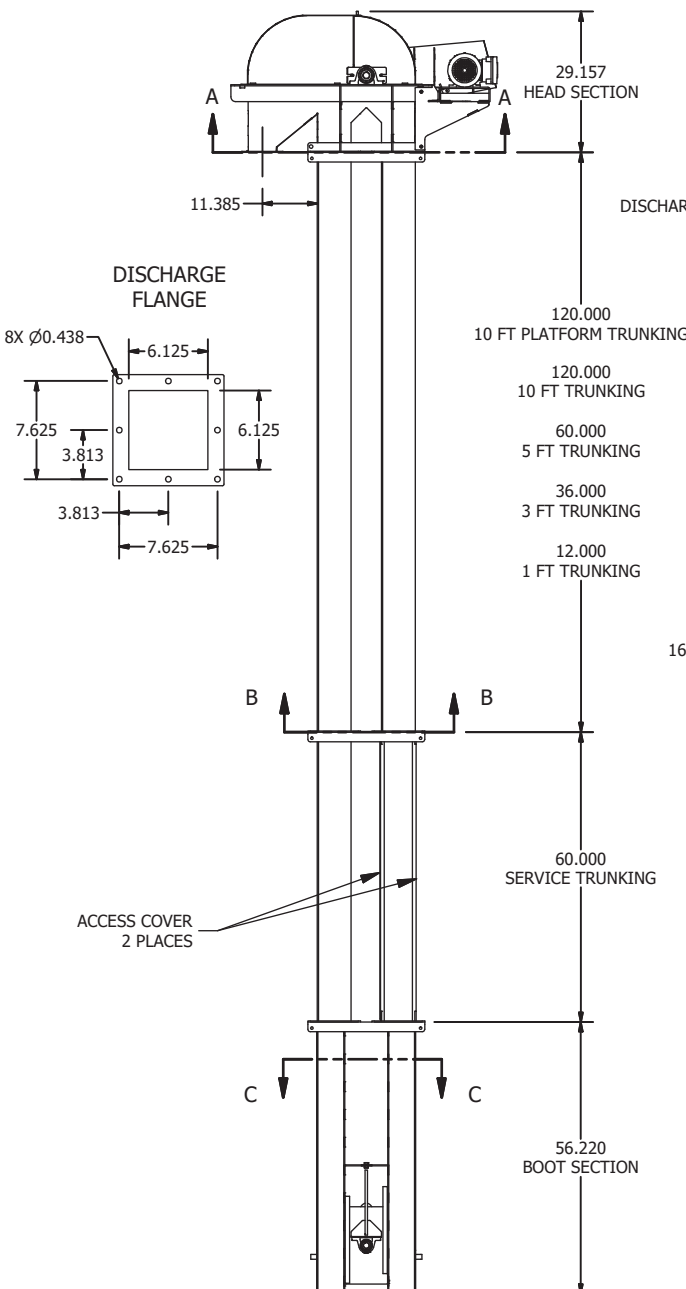
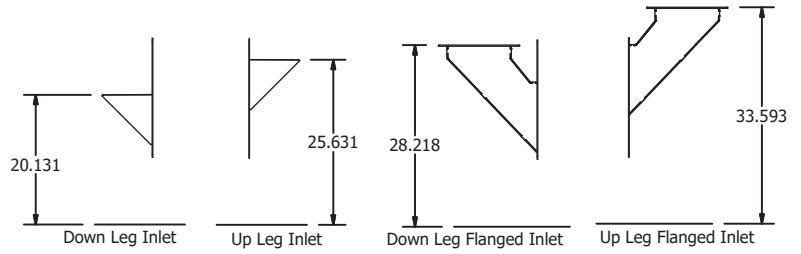
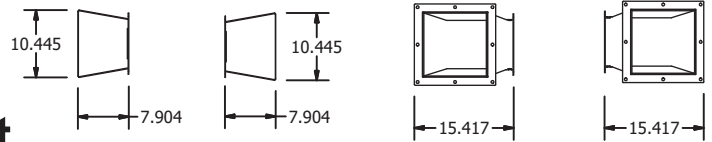

8" Drum x 9" Wide

