

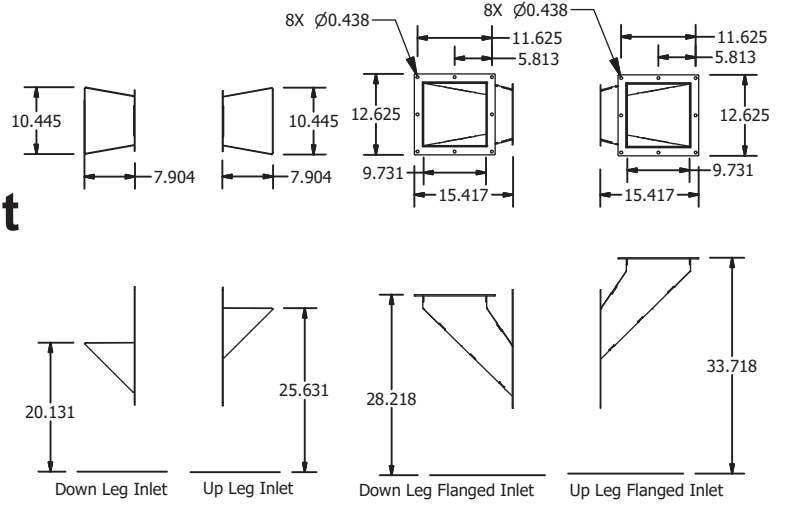

OPTIONAL: INLET PANELS



Bucket Elevator Spec Sheet
800 series Direct Drive

	Bushels per hour		
	500	700	1000
Cup Size	6" x 4"	6" x 4"	6" x 4"
Cup Spacing	12"	6"	6"
Head Shaft RPM	175	115	175
Belt FPM	358	235	358

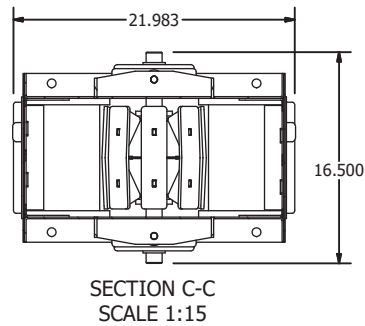
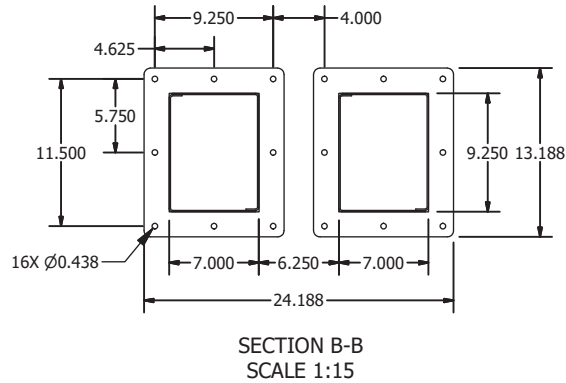
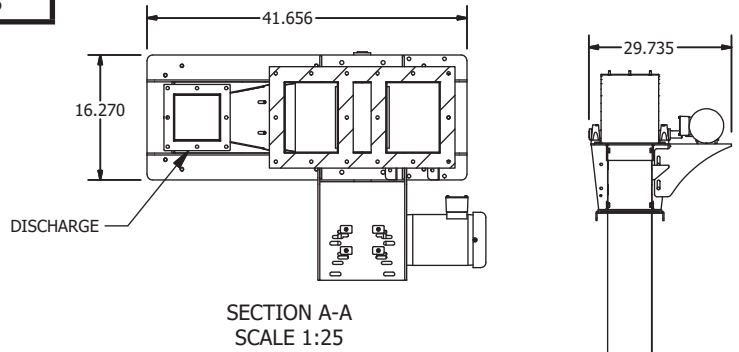
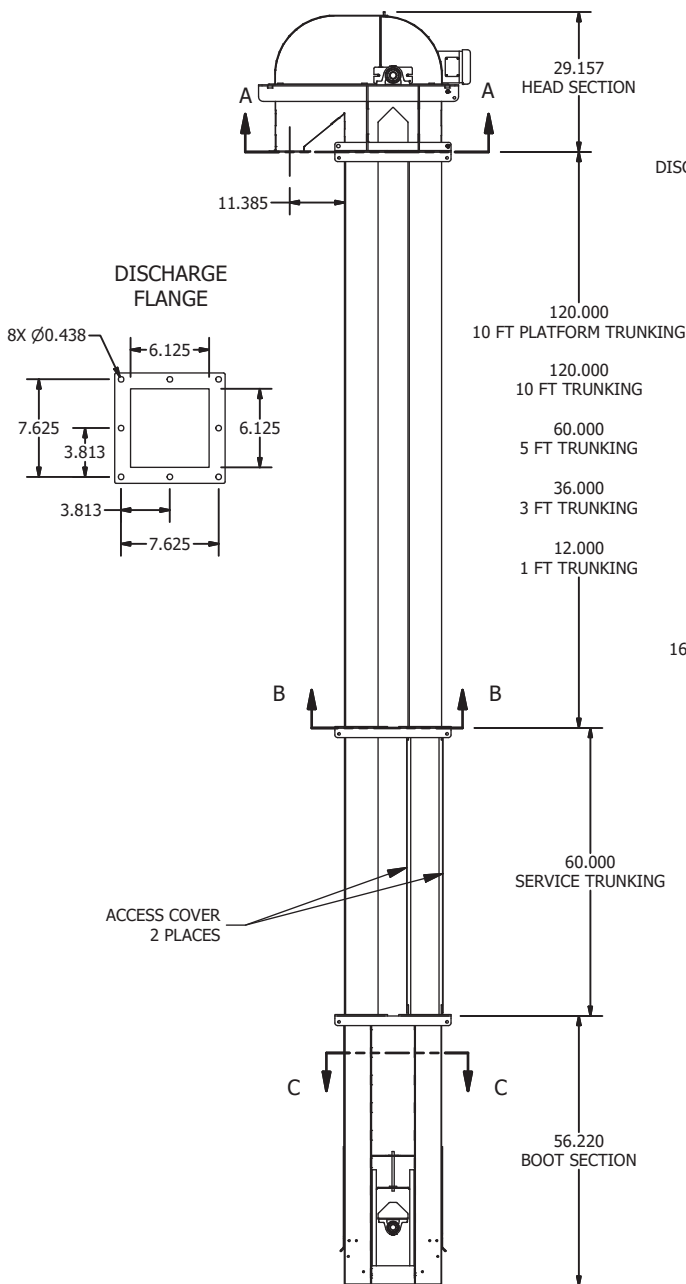

8" Drum x 9" Wide

